



ONation Corporation

TFT COLOR LCD MODULE

MODEL: OT104KXWDLV-H0

(Complied with RoHS)

XGA

LVDS interface(1 Port)

Version: P0.3

Customer : _____
Approved By : _____
Date: _____

ONATION		
APPROVAL	CHECKER	PREPARE

All information is subject to change without notice.
Please confirm the sales representative before starting to design your system

CONTENTS

NO.	ITEM	PAGE
1	RECORD OF REVISION	0-1
2	MECHANICAL SPECIFICATIONS	1
3	OUTLINE DIMENSIONS	2
4	INTERFACE PIN CONNECTION	3 ~ 4
5	BLOCK DIAGRAM	5
6	ABSOLUTE MAXIMUM RATINGS	6
7	ELECTRICAL CHARACTERISTICS	7
8	OPTICAL CHARACTERISTICS	8 ~ 10
9	TIMING SPECIFICATIONS	11 ~ 13
10	RELIABILITY TEST	14~ 15
11	LCM INSPECTION STANDARD	16
12	PACKAGE INFORMATION	16
13	PRECAUTIONS FOR USE	17

2.MECHANICAL SPECIFICATIONS

(1)	Number Of Dots (Dots)	1024R.G.B X 768
(2)	Module Size(mm)	236(W) X174.3(H) X 8.9 (D)
(3)	Active Area(mm)	211.2(W) X158.4(H)
(4)	Pixel Pitch(mm)	0.20625(W) X0.20625(H)
(5)	LCD / Polarizer Model	TFT , Transmissive Normally Black,Antiglare,Hard coating
(6)	LED Backlight Color	White
(7)	Viewing Direction	Wide viewing angle Horizontal :Right side 85°(Typ),Left side85°(Typ) Vertical: Up side 85°(Typ),Down side 85°(Typ)
(8)	Color Configuration	R.G.B Vertical Stripe
(9)	Interface	LVDS
(10)	Module Weight(g)	TBD

3. OUTLINE DIMENSIONS

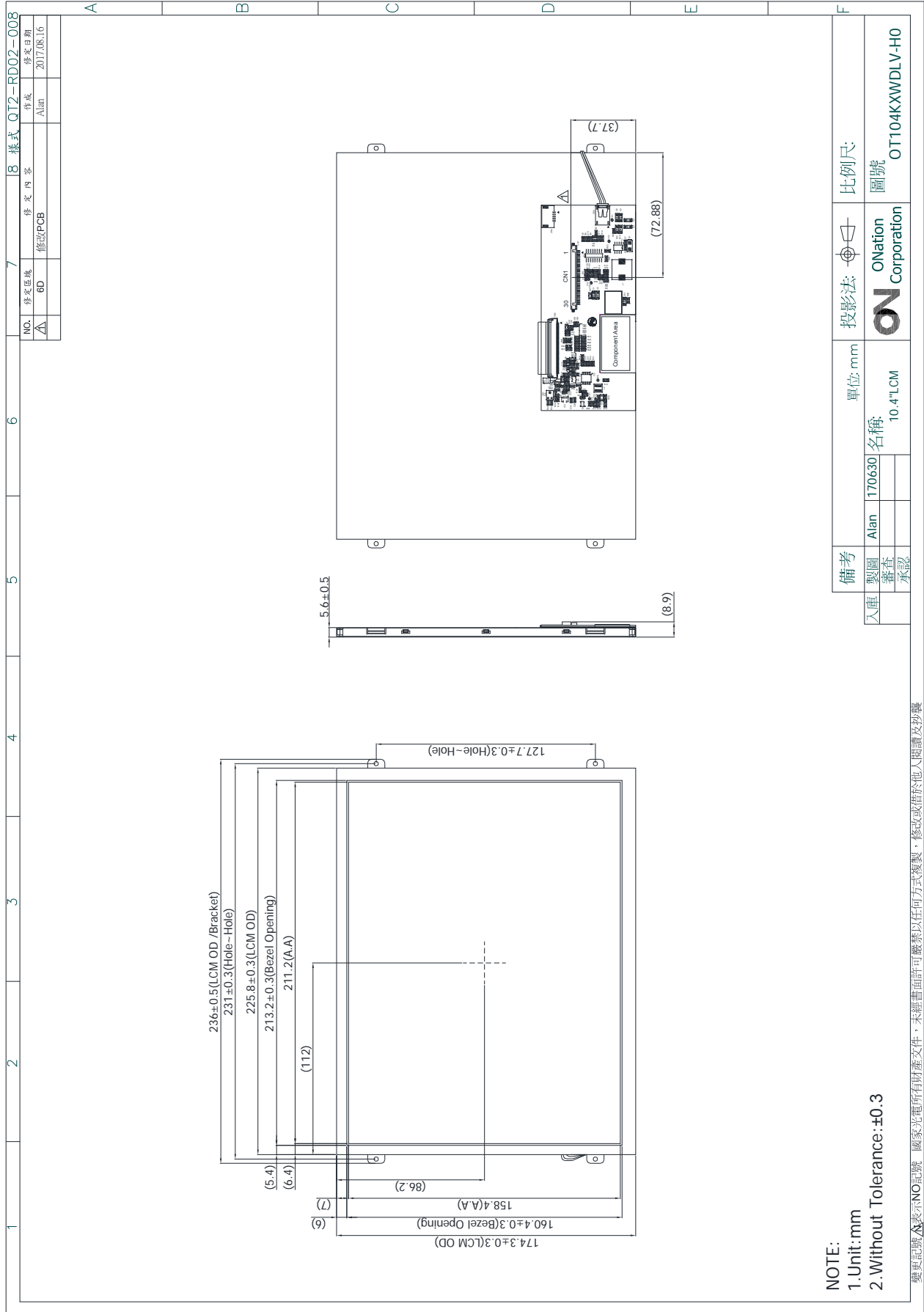

4. INTERFACE PIN CONNECTION

CN1 Connector : STM MSBK2407P30D or Equivalen

PIN NO.	SIGNAL	FUNCTION
1	GND	Ground
2	VDD	Power Supply For Digital Circuit
3	VDD	Power Supply For Digital Circuit
4	SELB	6/8 bits LVDS data input selection[H/NC:6bits;L:8bits]
5	UPDN	Vertical display mode select signal Up/Down Scan control input.
6	SHLR	Horizontal display mode select signal Left/Right Scan control input.
7	GND	Ground
8	RxIN0-	Differential Data Input, CH0(Negative)
9	RxIN0+	Differential Data Input, CH0(Positive)
10	GND	Ground
11	RxIN1-	Differential Data Input, CH1(Negative)
12	RxIN1+	Differential Data Input, CH1(Positive)
13	GND	Ground
14	RxIN2-	Differential Data Input, CH2(Negative)
15	RxIN2+	Differential Data Input, CH2(Positive)
16	GND	Ground
17	CLKIN-	Differential Clock Input(Negative)
18	CLKIN+	Differential Clock Input(Positive)
19	GND	Ground
20	RxIN3-	Differential Data Input, CH3(Negative)
21	RxIN3+	Differential Data Input, CH3(Positive)
22	GND	Ground
23	EN	Enable Control Signal od LED Converter
24	PWM	PWM Control Signal od LED Converter
25	GND	Ground
26	GND	Ground
27	GND	Ground
28	VLED	Converter input voltage
29	VLED	Converter input voltage
30	VLED	Converter input voltage

5. BLOCK DIAGRAM

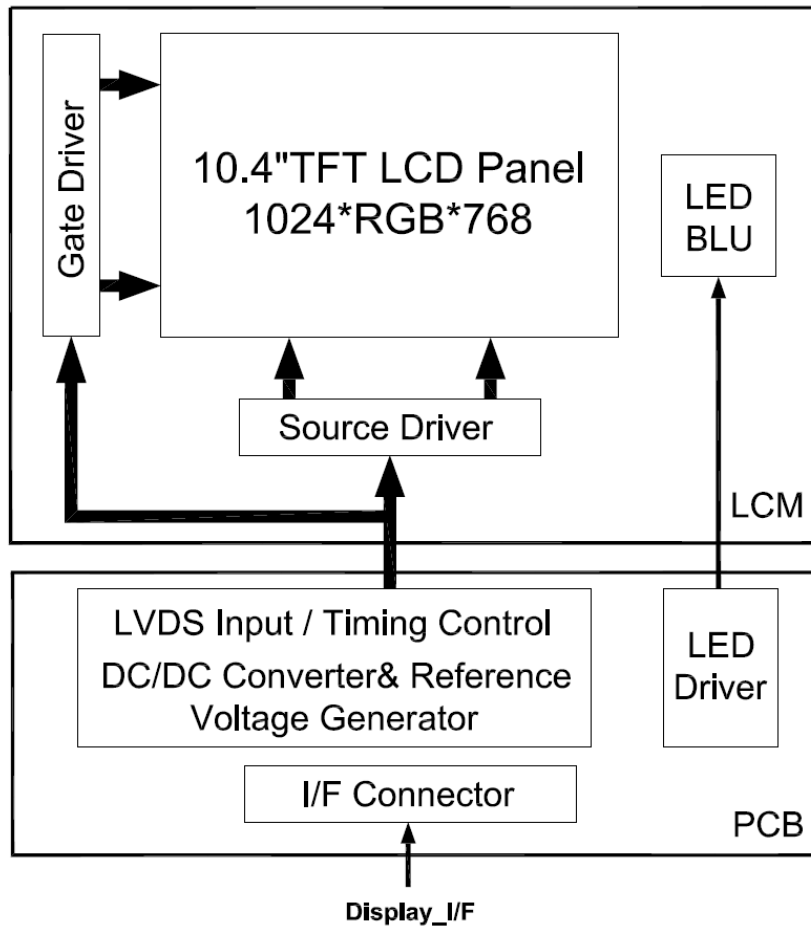

6.ABSOLUTE MAXIMUM RATINGS

6.1 ELECTRICAL ABSOLUTE MAXIMUM RATINGS

ITEM	SYMBOL	MIN.	MAX.	UNIT	REMARK
Supply Voltage	VCC	-0.3	+3.9	V	
	VLED	-0.3	+36.0	V	

Note: The absolute maximum rating values of this product not allowed to be exceeded at any times. Should be module be used with any of absolute maximum ratings exceeded. The characteristics of the module may not be recovered, or in an extreme case, the module may be permanently destroyed.

6.2 ENVIRONMENTAL ABSOLUTE MAXIMUM RATINGS

ITEM	OPERATING		STORAGE		REMARK
	MIN.	MAX.	MIN.	MAX.	
Ambient Temperature(°C)	-20	(70)	-30	(80)	Note 1,2
Humidity(% RH)	5 ~ 90		5 ~ 90		Note 3

Note 1 : The response time will become lower when operated at low temperature.

Note 2 : Background color changes slightly depending on ambient temperature.

Note 3 : Operating Ta=(60°C) & RH=90% ≤ 240Hrs.

7.ELECTRICAL CHARACTERISTICS

7.1 ELECTRICAL CHARACTERISTICS OF LCD

Ta=25°C

ITEM	SYMBOL	MIN.	TYP.	MAX.	UNIT	REMARK
Power Voltage For LCD	VDD	2.5	-	3.3	V	
	IDD	-	TBD	TBD	mA	Note 1
Differential Input Threshold Voltage	VIH	0.8VDD	-	VDD	mV	
	VIL	0	-	0.2VDD	mV	

Note 1 : Test condition : VDD=3.3V ; Test Pattern : White

7.2 BACKLIGHT UNITS

Ta=25°C

ITEM		SYMBOL	MIN.	TYP.	MAX.	UNIT
LED Driving Voltage		VLED	9.0	12.0	15.0	V
		ILED (VLED=12.0V)	-	TBD	TBD	A
PWM Control Level	PWM High Level	-	3.0	3.3	3.6	V
	PWM Low Level	-	0	-	1.0	V
PWM Control Duty Ratio		-	0	-	100	%
PWM Control Frequency		f _{PWM}	100	-	2000	Hz
LED Life Time (For Reference Only)		Ta=25°C 60-70%RH (Note 1)	-	50,000	-	Hr

Note 1: The LED of B/L is drive by current only, drive voltage is for reference only. drive voltage can make driving current under safety area(current between minimum and maximum). 50,000 hours is only an estimate for reference.

Note 2: The lifetime of LED is defined as the time when it continues to operate under the conditions at Ta= 25 ±2°C and PWM=100% until the brightness becomes ≤50% of its original value.

8.OPTICAL CHARACTERISTICS

Ta=25°C

ITEM		SYMBOL	CONDITIONS	MIN.	TYP.	MAX.	UNIT	REMARK
Contrast Ratio		CR	Viewing Normal Angle $\Theta_x = \Theta_y = 0^\circ$	600	900	-	-	Note 1
Response Time		TR+TF		-	30	40	ms	Note 2
Color chromaticity	White	x	$\Theta_x = \Theta_y = 0^\circ$	(0.26)	(0.31)	(0.36)	-	
		y		(0.28)	(0.33)	(0.38)	-	
Viewing Angle	Hor.	θ_L	Viewing Angle $\Theta_x = \Theta_y = 0^\circ$ $CR \geq 10$	75	85	-	Deg.	Note 3
		θ_R		75	85	-		
	Ver.	θ_T		75	85	-		
		θ_B		75	85	-		
Luminance		L	PWM=100%	-	(1000)	-	cd/m2	
Luminance Uniformity		YU		70	80	-	%	Note 5

Note 1 : Definition of Contrast Ratio (CR) :

The contrast ratio can be calculated by the following expression.

$$\text{Contrast Ratio (CR)} = L_{63}/L_0$$

L63 : Luminance of gray level 63

L0 : Luminance of gray level 0

$$CR = CR(5)$$

CR(X) is corresponding to the Contrast Ratio of the point X at Figure in Note 5

Note 2 : Definition of Response Time (TR,TF)

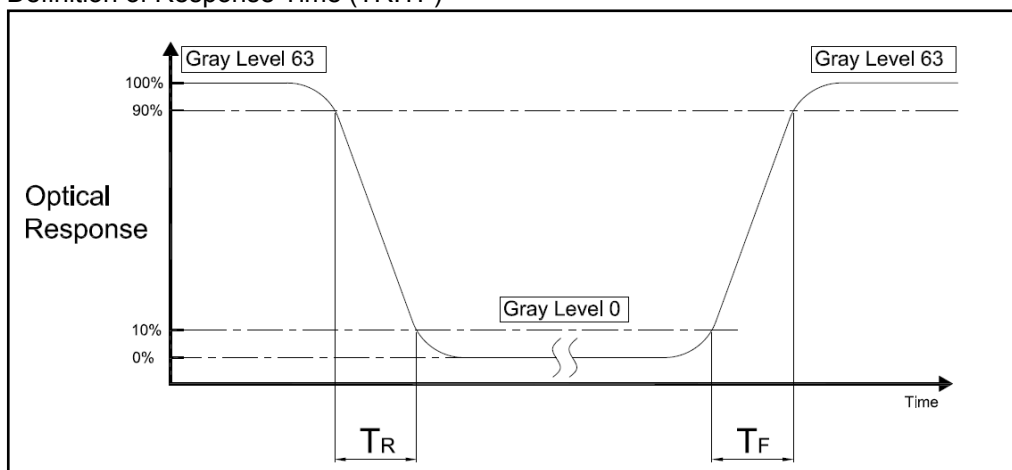

Note 3 : Definition of Viewing Angle

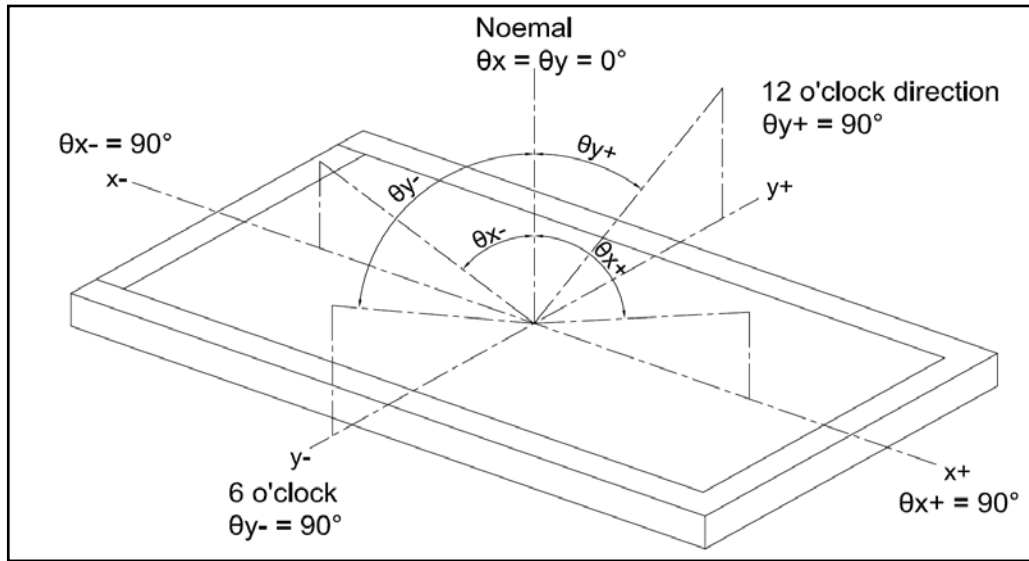

Note 4 : Measurement Set-Up:

The LCD module should be stabilized at a given temperature for 20 minutes to avoid abrupt temperature change during measuring. In order stabilize the luminance, the measurement should be executed after lighting Backlight for 20 minutes in a windless room.

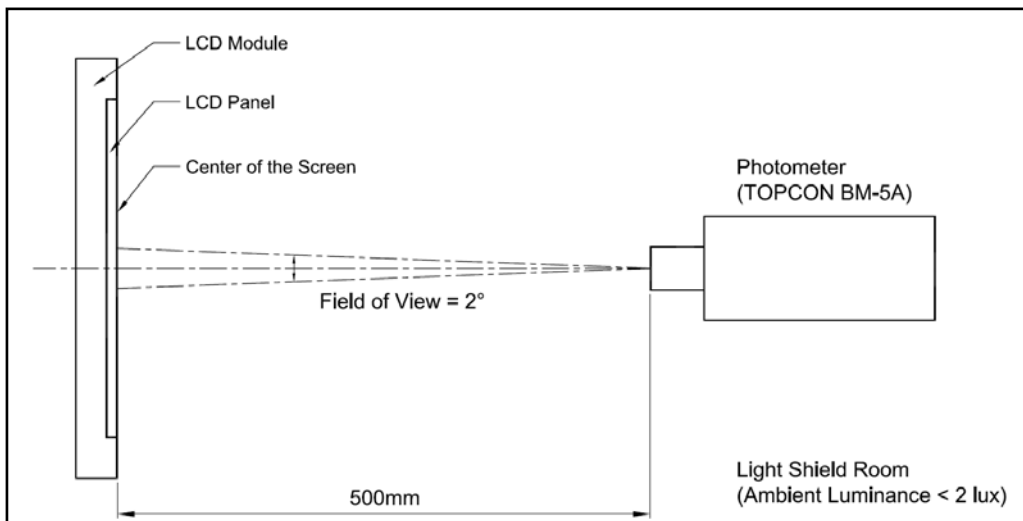

\

Note 5 :

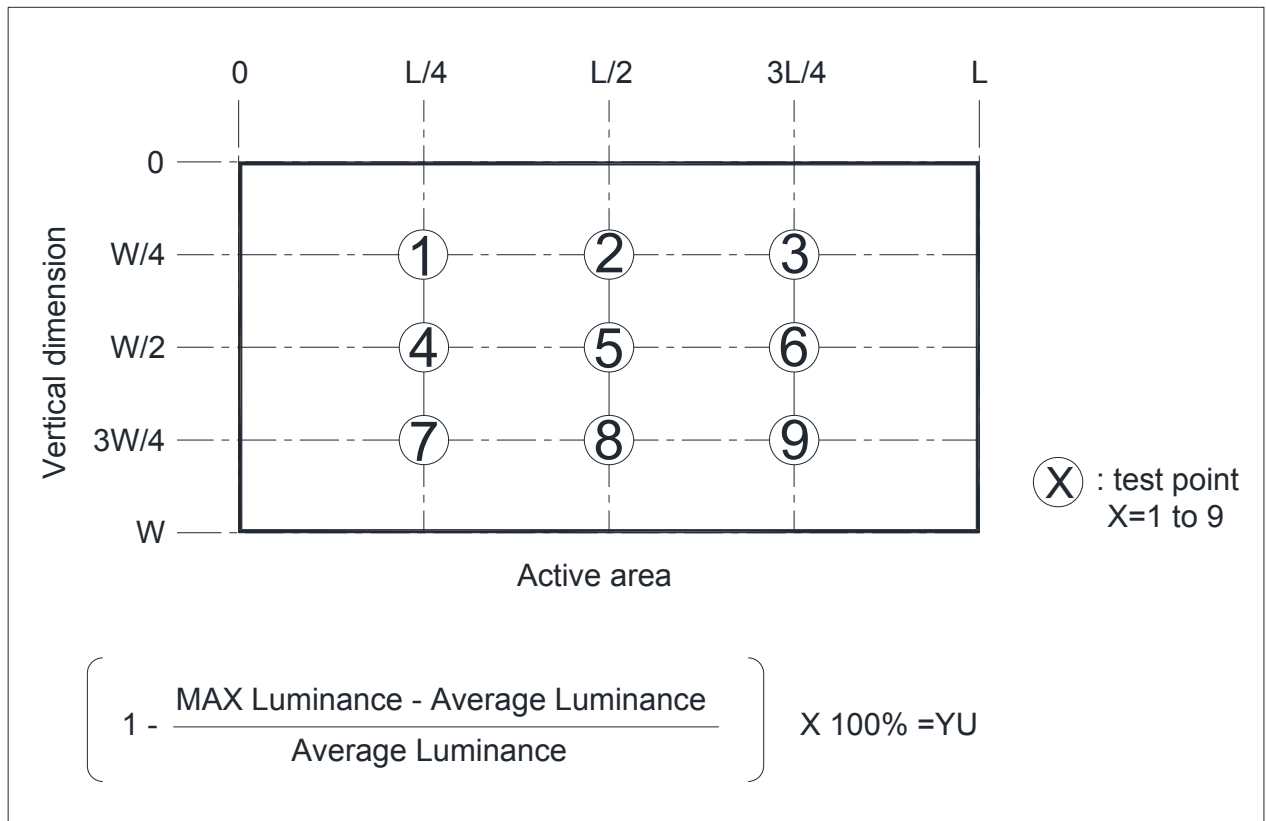

9. TIMING SPECIFICATIONS

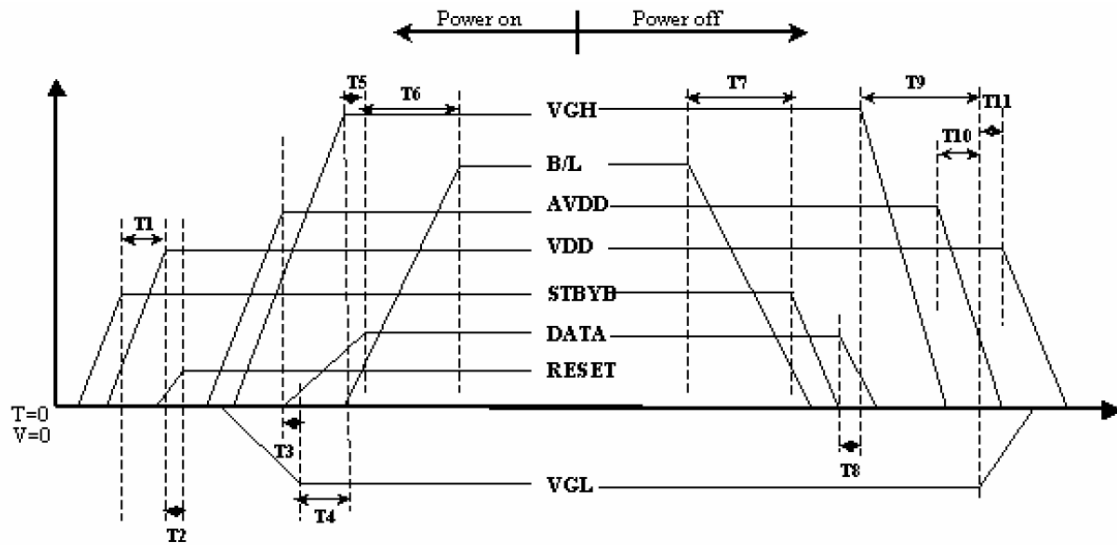

Item	Min.	Typ.	Max.	Unit
T1	0	--	--	ms
T2	50	--	--	ms
T3	5	--	--	ms
T4	10	--	--	ms
T5	20	--	--	ms
T6	50	--	--	ms
T7	20	--	--	ms
T8	10	--	--	ms
T9	20	--	--	ms
T10	10	--	--	ms
T11	20	--	--	ms

9.2 RESET TIMING CHARACTERISTICS

DE mode					
Parameter	Symbol	Value			Unit
		Min.	Typ.	Max.	
DCLK frequency @Frame rate=60hz	fclk	52	65	71	Mhz
Horizontal display area	thd	1024			DCLK
HSYNC period time	th	1114	1344	1400	DCLK
HSYNC blanking	thb+thfp	90	320	376	DCLK
Vertical display area	tvd	768			H
VSYNC period time	tv	778	806	845	H
VSYNC blanking	tvb+tvfp	10	38	77	H

Timing Diagram of Interface Signal (DE mode)

(1). Vertical input timing

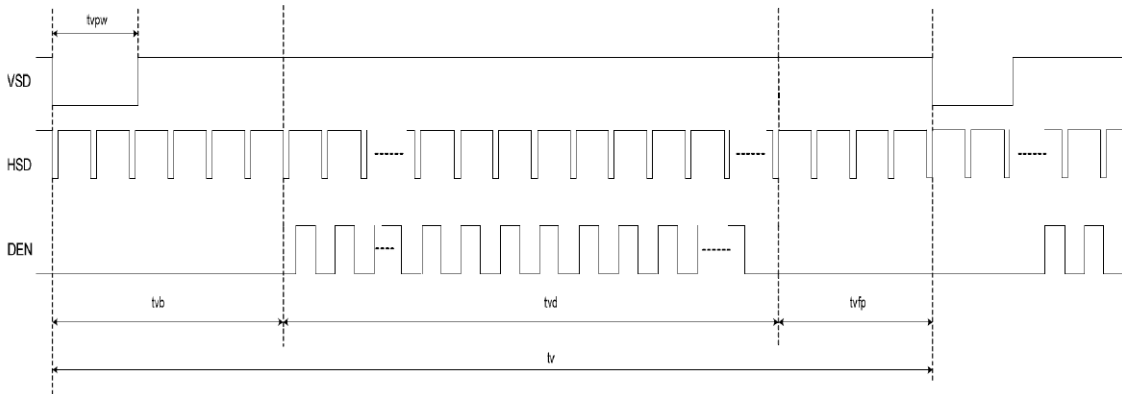

(2). Horizontal input timing

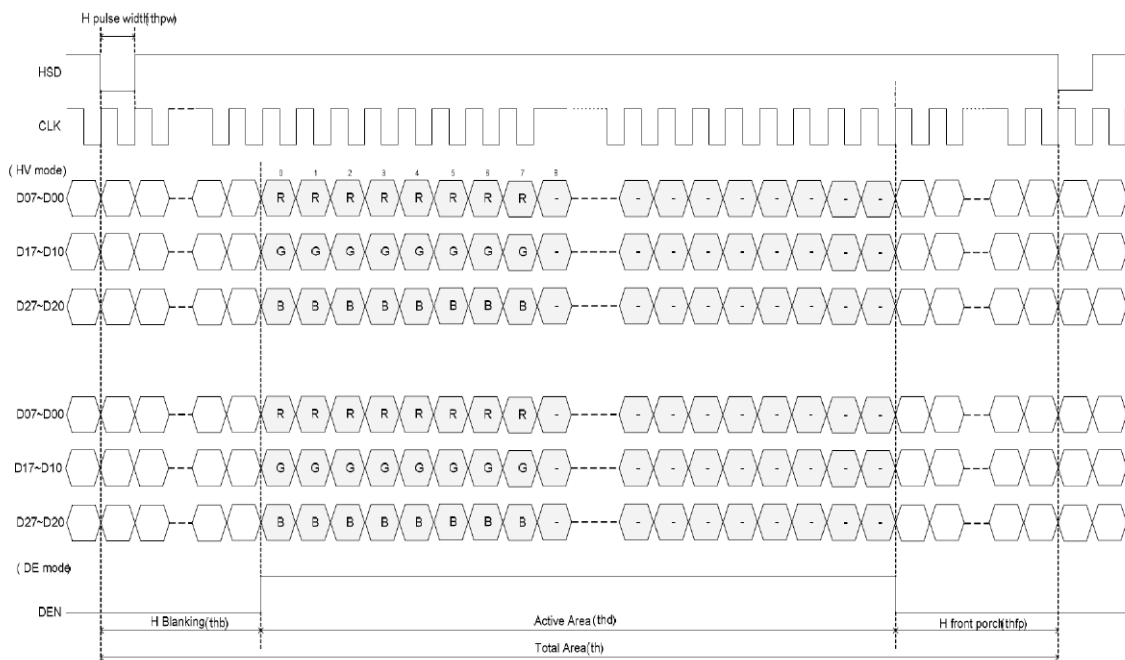

9.3 Bit LVDS Input

6bit LVDS input

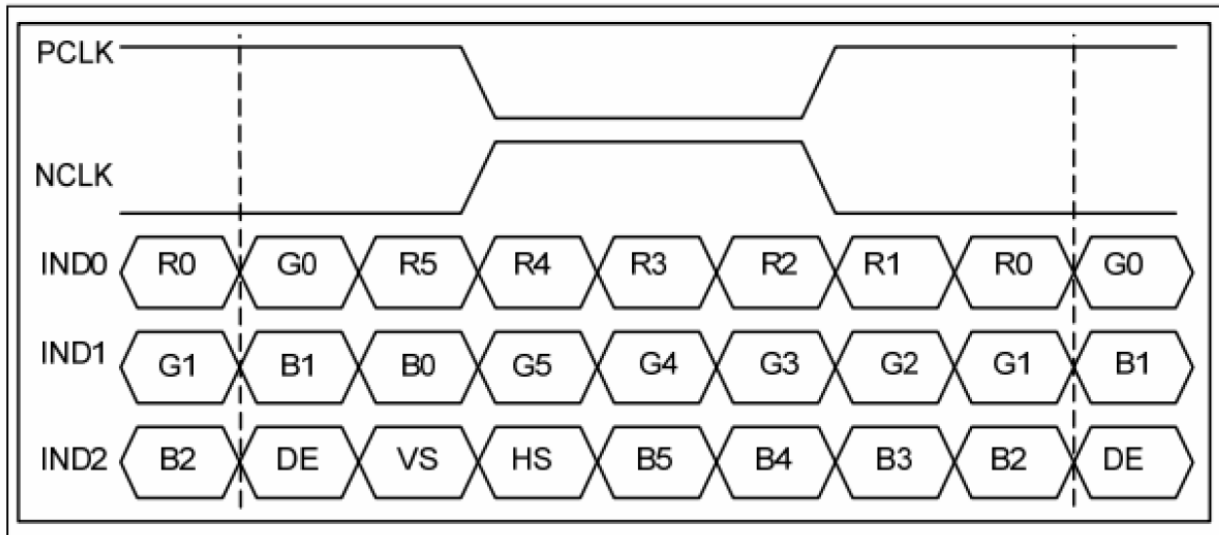

8Bit LVDS input

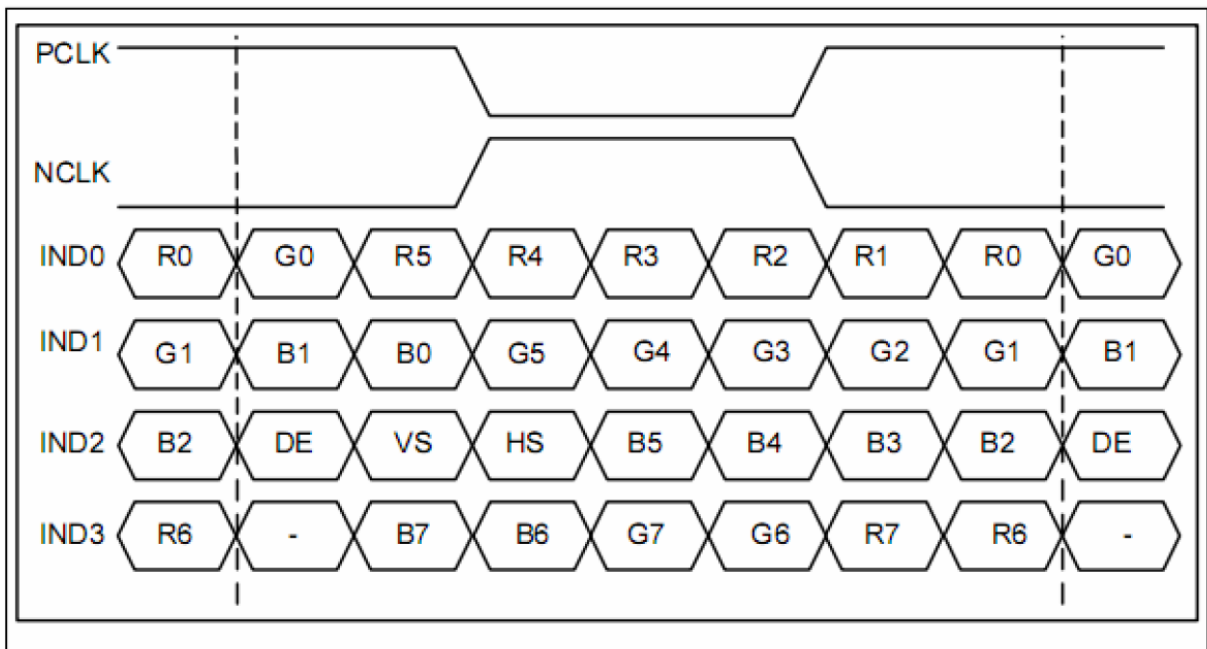

10. RELIABILITY TEST

ENVIRONMENTAL TEST				
NO.	ITEM	CONDITIONS	TIME PERIOD	REMARK
1	High Temperature Storage	(80°C)	240Hours	Note 1,4
2	Low Temperature Storage	-30°C	240Hours	Note 1,4
3	High Temperature Humidity Operation	(60°C),90%RH	240Hours	Note 4
4	High Temperature Operation	(70°C)	240Hours	Note 2,4
5	Low Temperature Operation	-20°C	240Hours	Note1,4
6	Temperature Cycle	-20°C ~ (70°C) (30min) (30min)	100CYCLE	Note 4

Note1 : Ta is the ambient temperature of samples.

Note2 : Ts is the temperature of panel's surface.

Note3 : In the standard condition, there shall be no practical problem that may affect the display function. After the reliability test, the product only guarantees operation, but don't guarantee all of the cosmetic specification.

Note4 : Before cosmetic and function test, the product must have enough recovery time, at least 2 hours at room temperature.

10.1 VIBRATION TEST:

10.1.1 STATE LABORATORY ENVIRONMENT :

Room temperature : $25\pm 3^{\circ}\text{C}$
Relative humidity : $55\pm 20\%RH$

10.1.2 TEST METHOD / SPECIFICATION :

Sample Status : Non-packaged single state
Waveform : Sine
Frequency : 10~55HZ
Full amplitude : 1.5mm
Vibration direction : X,Y,Z Axis(3 Axial)
Test time : Each 120minZ Axis , Altogether 360min

10.2 MECHANICAL SHOCK TEST :

10.1.1 STATE LABORATORY ENVIRONMENT :

Room temperature : $25\pm 3^{\circ}\text{C}$
Relative humidity : $55\pm 20\%RH$

10.1.2 TEST METHOD / SPECIFICATION :

Sample Status : Non-packaged single state
Waveform : Half-sine
Acceleration : 50G
Shock Time : 6ms
Impact direction : 3Directions($\pm X, \pm Y, \pm Z$ axes)
Number of shocks : Each direction 3 Secondary , Altogether 18 Secondary

11. LCM INSPECTION STANDARD

Inspection specifications refer ONation Corporation LCM INSPECTION STANDARD Document.
Document Number : TBD

12. PACKAGE INFORMATION

LCM Model	LCM Qty. in the box	Inner Box Size (mm)	Weight	REMARK
OT104KXWDLV-H0	TBD	TBD	TBD	

13. PRECAUTIONS FOR USE

13.1 SAFETY

- (1) Do not swallow any liquid crystal, even if there is no proof that liquid crystal is poisonous.
- (2) If the LCD panel breaks, be careful not to get liquid crystal to touch your skin.
- (3) If skin is exposed to liquid crystal, wash the area thoroughly with alcohol or soap.

13.2 STORAGE CONDITIONS

- (1) Store the panel or module in a dark place where the temperature is $23\pm 5^{\circ}\text{C}$ and the humidity is below $50\pm 20\% \text{RH}$.
- (2) Store in anti-static electricity container.
- (3) Store in clean environment, free from dust, active gas, and solvent.
- (4) Do not place the module near organics solvents or corrosive gases.
- (5) Do not crush, shake, or jolt the module.

13.3 HANDLING PRECAUTIONS

- (1) Avoid static electricity which can damage the CMOS LSI.
- (2) The polarizing plate of the display is very fragile. So, please handle it very carefully.
- (3) Do not give external shock.
- (4) Do not apply excessive force on the surface.
- (5) Do not wipe the polarizing plate with a dry cloth, as it may easily scratch the Surface of plate.
- (6) Do not use ketonics solvent & Aromatic solvent, use with a soft cloth soaked with a cleaning naphtha solvent.
- (7) Do not operate it above the absolute maximum rating.
- (8) Do not remove the panel or frame from the module.
- (9) When the module is assembled, it should be attached to the system firmly, Be careful not to twist and bend the module.
- (10) Wipe off water droplets or oil immediately . If you leave the droplets for a long time, staining and discoloration may occur.
- (11) If the liquid crystal material leaks from the panel, it should be kept away from the eyes or mouth. In case of contact with hands, legs or clothes, it must be washed away thoroughly with soap.

13.4 WARRANTY

- (1) Acceptance inspection period
The period is within one month after the arrival of contracted commodity at the buyer's factory site.
- (2) Applicable warrant period
The period is within 12 months since the date of shipping out under normal using and storage conditions.